

MODEL L-1560

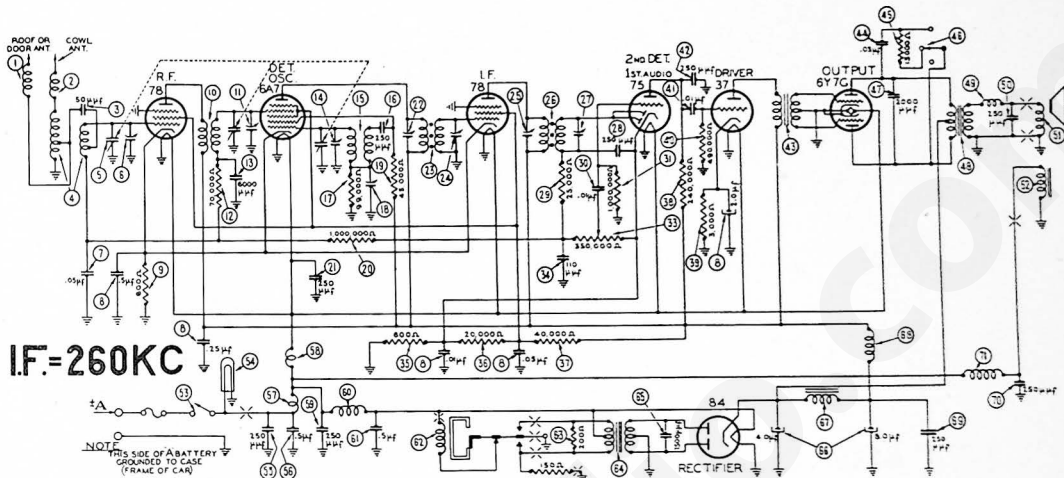

Aligning Procedure will be found on page 167.

MODEL L-1560 PARTS LIST

No.	Description	Part No.	No.	Description	Part No.
①	Antenna Choke	38-8106	④④	Condenser (.03 mfd.)	30-4447
②	Antenna Choke	38-8106	④⑤	Resistor (15,000 ohms)	33-315344
③	Condenser (50 mmfd.)	30-1029	④⑥	Tone Control Switch	42-1577
④	Antenna Transformer	32-2914	④⑦	Condenser (2,000 mmfd.)	30-4177
⑤	Tuning Condenser	31-2161	④⑧	Output Transformer	32-7778
⑥	First Padder (on Tun. Cond.)		④⑨	Choke	32-1374
⑦	Condenser (.05 mfd.)	30-4444	④⑩	Condenser (250 mmfd.)	30-1032
⑧	Condenser (.01-.05-.25-.5-2 mfd.)	30-4493	④⑪	Cone & Voice Coil	36-3159
⑨	Resistor (600 ohms)	33-1212	④⑫	Field Coil Assembly	36-3513
⑩	R. F. Transformer	32-2830	④⑬	On & Off Switch	42-1369
⑪	Second Padder (on Tun. Cond.)		④⑭	Pilot Lamp	34-2039
⑫	Resistor (70,000 ohms)	33-370344	④⑮	Condenser (250 mmfd.)	30-1032
⑬	Condenser (6,000 mmfd.)	30-4467	④⑯	Condenser (.5 mfd.)	30-4474
⑭	Third Padder (on Tun. Cond.)		④⑰	"A" Choke	32-1374
⑮	Oscillator Transformer	32-2829	④⑱	Filament Choke	32-2729
⑯	Condenser (250 mmfd.)	30-1032	④⑲	Condenser (250 mmfd.)	30-1032
⑰	Resistor (99,000 ohms)	33-390344	④⑳	Vibrator Choke	32-2537
⑱	Low Frequency Padder	31-6230	④㉑	Condenser (.5 mfd.)	30-4474
⑲	Resistor (45,000 ohms)	33-345344	④㉒	Resistor (200 ohms)	33-120344
⑳	Resistor (1,000,000 ohms)	33-510344	④㉓	Power Transformer	32-7720
㉑	Condenser (250 mmfd.)	30-1032	④㉔	Condenser (7,500 mmfd.)	30-4420
㉒	Padder (Pri. 1st I. F. Trans.)		④㉕	Filter Condenser (4-8 mfd.)	30-2167
㉓	First I. F. Transformer	32-2791	④㉖	Filter Choke	32-7811
㉔	Padder (Sec. 1st I. F. Trans.)		④㉗	"B" Choke	32-1281
㉕	Padder (Pri. 2nd I. F. Trans.)		④㉘	Condenser (250 mmfd.)	30-1032
㉖	Second I. F. Transformer	32-2793	④㉙	Condenser (250 mmfd.)	30-1032
㉗	Padder (Sec. 2nd I. F. Trans.)		④㉚	Choke	32-2657
㉘	Condenser (250 mmfd.)	30-1032	④㉛	Receiver Housing	38-9340
㉙	Resistor (25,000 ohms)	33-325344	④㉜	Four Prong Socket	27-6044
㉚	Condenser (.01 mfd.)	30-4479	④㉝	Five Prong Socket	27-6035
㉛	Resistor (1,000,000 ohms)	33-510344	④㉞	Six Prong Socket	27-6036
㉜	Volume Control (350,000 ohms)	33-5246	④㉟	Seven Prong Socket	27-6037
㉝	Condenser (110 mmfd.)	30-1031	④㊱	Seven Prong Socket	27-6087
㉞	Resistor (600 ohms)	33-160331	④㊲	Aerial Base	27-7227
㉟	Resistor (20,000 ohms)	33-320344	④㊳	Fuse	27-7729
㊱	Resistor (40,000 ohms)	33-340444	④㊴	Fuse Insulator	28-8821
㊲	Resistor (240,000 ohms)	33-424344	④㊵	Tuning Shaft	28-8822
㊳	Resistor (3,000 ohms)	33-230344	④㊶	Volume Shaft	28-8823
㊴	Resistor (400,000 ohms)	33-449344	④㊷	Scale Assembly	42-3803
㊵	Condenser (.01 mfd.)	30-4145	④㊸	Tuning & Volume Knob	27-4691
㊶	Condenser (250 mmfd.)	30-1032	④㊹	Knob Base	28-7284
㊷	Input Transformer	32-7779	④㊺	Switch Lever	28-7255

